

A decorative graphic consisting of several overlapping blue circles of varying sizes and shades, arranged in a vertical line. A thin black horizontal line is positioned above the top circle. Two thin blue diagonal lines cross the page, one from the top-left to the bottom-right, and another from the top-right to the bottom-left, intersecting the circles.

# ALLEN BRADLEY 1785-L30B DATASHEET

CAMBIA AUTOMATION LIMITED  
EMAIL: SALES@CAMBIA.CN

**CAMBIA GROUP**  
**2018/12/12**



## Enhanced PLC-5 Programmable Controllers

Cat. Nos. 1785-L11B, -L20B, -L30B, -L40B, -L40L, -L60B, -L60L, -L80B

### Purpose of This Document

This document describes how to install and troubleshoot your Enhanced PLC-5® programmable controller. For more information, see the documents listed on the following page or contact your local Rockwell Automation representative.

These installation instructions:

- provide the basic information you need to get your system up and running
- provide specific bit and switch settings for modules
- include high-level procedures with cross-references to other manuals for more detail

### What This Document Describes

<b>For this information:</b>	<b>See page:</b>
Important User Information	2
How to Obtain a User Manual	5
Related Documentation	5
Enhanced PLC-5 Programmable Controller Overview	6
Install the System Hardware	8
Troubleshoot the Controller	17
Controller Specifications	20
Rockwell Automation Support	24

## Important User Information

Solid state equipment has operational characteristics differing from those of electromechanical equipment. *Safety Guidelines for the Application, Installation and Maintenance of Solid State Controls* (Publication SGI-1.1 available from your local Rockwell Automation sales office or online at <http://www.ab.com/manuals/gi>) describes some important differences between solid state equipment and hard-wired electromechanical devices. Because of this difference, and also because of the wide variety of uses for solid state equipment, all persons responsible for applying this equipment must satisfy themselves that each intended application of this equipment is acceptable.

In no event will Rockwell Automation, Inc. be responsible or liable for indirect or consequential damages resulting from the use or application of this equipment.

The examples and diagrams in this manual are included solely for illustrative purposes. Because of the many variables and requirements associated with any particular installation, Rockwell Automation, Inc. cannot assume responsibility or liability for actual use based on the examples and diagrams.

No patent liability is assumed by Rockwell Automation, Inc. with respect to use of information, circuits, equipment, or software described in this manual.

Reproduction of the contents of this manual, in whole or in part, without written permission of Rockwell Automation, Inc. is prohibited.

Throughout this manual we use notes to make you aware of safety considerations.

### WARNING



Identifies information about practices or circumstances that can cause an explosion in a hazardous environment, which may lead to personal injury or death, property damage, or economic loss.

### IMPORTANT

Identifies information that is critical for successful application and understanding of the product.

### ATTENTION



Identifies information about practices or circumstances that can lead to personal injury or death, property damage, or economic loss. Attentions help you:

- identify a hazard
- avoid a hazard
- recognize the consequence

### SHOCK HAZARD



Labels may be located on or inside the equipment to alert people that dangerous voltage may be present.

### BURN HAZARD



Labels may be located on or inside the drive to alert people that surfaces may be dangerous temperatures.

## North American Hazardous Location Approval

### The following information applies when operating this equipment in hazardous locations:

Products marked "CL I, DIV 2, GP A, B, C, D" are suitable for use in Class I Division 2 Groups A, B, C, D, Hazardous Locations and nonhazardous locations only. Each product is supplied with markings on the rating nameplate indicating the hazardous location temperature code. When combining products within a system, the most adverse temperature code (lowest "T" number) may be used to help determine the overall temperature code of the system. Combinations of equipment in your system are subject to investigation by the local Authority Having Jurisdiction at the time of installation.

### Informations sur l'utilisation de cet équipement en environnements dangereux :

Les produits marqués "CL I, DIV 2, GP A, B, C, D" ne conviennent qu'à une utilisation en environnements de Classe I Division 2 Groupes A, B, C, D dangereux et non dangereux. Chaque produit est livré avec des marquages sur sa plaque d'identification qui indiquent le code de température pour les environnements dangereux. Lorsque plusieurs produits sont combinés dans un système, le code de température le plus défavorable (code de température le plus faible) peut être utilisé pour déterminer le code de température global du système. Les combinaisons d'équipements dans le système sont sujettes à inspection par les autorités locales qualifiées au moment de l'installation.

#### EXPLOSION HAZARD

##### WARNING



- Do not disconnect equipment unless power has been removed or the area is known to be nonhazardous.
- Do not disconnect connections to this equipment unless power has been removed or the area is known to be nonhazardous. Secure any external connections that mate to this equipment by using screws, sliding latches, threaded connectors, or other means provided with this product.
- Substitution of components may impair suitability for Class I, Division 2.
- If this product contains batteries, they must only be changed in an area known to be nonhazardous.

##### AVERTISSEMENT



#### RISQUE D'EXPLOSION

- Couper le courant ou s'assurer que l'environnement est classé non dangereux avant de débrancher l'équipement.
- Couper le courant ou s'assurer que l'environnement est classé non dangereux avant de débrancher les connecteurs. Fixer tous les connecteurs externes reliés à cet équipement à l'aide de vis, loquets coulissants, connecteurs filetés ou autres moyens fournis avec ce produit.
- La substitution de composants peut rendre cet équipement inadapté à une utilisation en environnement de Classe I, Division 2.
- S'assurer que l'environnement est classé non dangereux avant de changer les piles.

## Environment and Enclosure

**ATTENTION**



- This equipment is intended for use in a Pollution Degree 2 industrial environment, in overvoltage Category II applications (as defined in IEC publication 60664-1), at altitudes up to 2000 meters without derating.
- This equipment is considered Group 1, Class A industrial equipment according to IEC/CISPR Publication 11. Without appropriate precautions, there may be potential difficulties ensuring electromagnetic compatibility in other environments due to conducted as well as radiated disturbance.
- This equipment is supplied as "open type" equipment. It must be mounted within an enclosure that is suitably designed for those specific environmental conditions that will be present and appropriately designed to prevent personal injury resulting from accessibility to live parts. The interior of the enclosure must be accessible only by the use of a tool. Subsequent sections of this publication may contain additional information regarding specific enclosure type ratings that are required to comply with certain product safety certifications.

NOTE: See NEMA Standards publication 250 and IEC publication 60529, as applicable, for explanations of the degrees of protection provided by different types of enclosure. Also, see the appropriate sections in this publication, as well as the Allen-Bradley publication 1770-4.1 ("Industrial Automation Wiring and Grounding Guidelines"), for additional installation requirements pertaining to this equipment.

---

## How to Obtain a User Manual

The related user manual contains detailed information about configuring, programming, and using an Enhanced PLC-5 controller. To obtain a copy of the Enhanced and Ethernet PLC-5 Programmable Controllers User Manual, publication number 1785-UM012, you can either:

- view or download an electronic version from the internet at [www.rockwellautomation.com/literature](http://www.rockwellautomation.com/literature)
- contact your local distributor or Rockwell Automation representative to place an order

## Related Documentation

The following documents contain additional information related to the products described in this document.

For more information about:	See this document:	Publication number
Enhanced PLC-5 programmable controllers	Enhanced and Ethernet PLC-5 Programmable Controllers User Manual	1785-UM012
Universal 1771 I/O chassis	Universal I/O Chassis Installation Instructions	1771-IN075
power supply	Power Supply Modules (1771-P4S, -P6S, -P4S1, -P6S1) Installation Instructions	1771-IN079
DH+® network, extended-local I/O	Enhanced and Ethernet PLC-5 Programmable Controllers User Manual Data Highway/Data Highway Plus/Data Highway II/Data Highway-485 Cable Installation Instructions	1785-UM012 1770-6.2.2
communication cards	1784-KTx Communication Interface Card User Manual	1784-6.5.22
cables	Enhanced and Ethernet PLC-5 Programmable Controllers User Manual	1785-UM012
batteries	Allen-Bradley Guidelines for Lithium Battery Handling and Disposal	AG-5.4
grounding and wiring Allen-Bradley programmable controllers	Allen-Bradley Programmable Controller Wiring and Grounding Guidelines	1770-4.1
terms and definitions	Allen-Bradley Industrial Automation Glossary	AG-7.1

# Enhanced PLC-5 Programmable Controller Overview

The following illustrations indicate the controller's front panel components.

## PLC-5/11, -5/20, and -5/26 Controller Front Panel

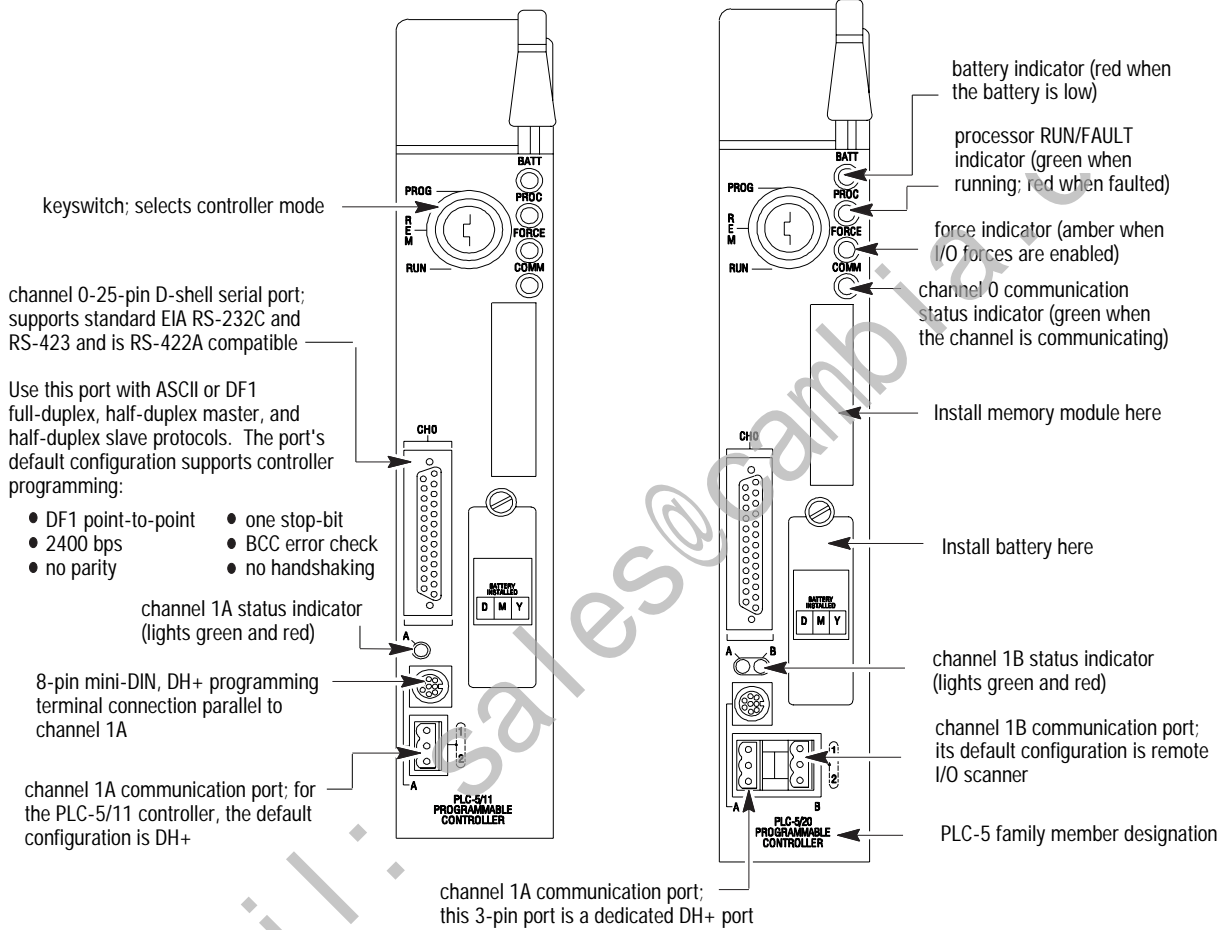

### PLC-5/30 Controller Front Panel

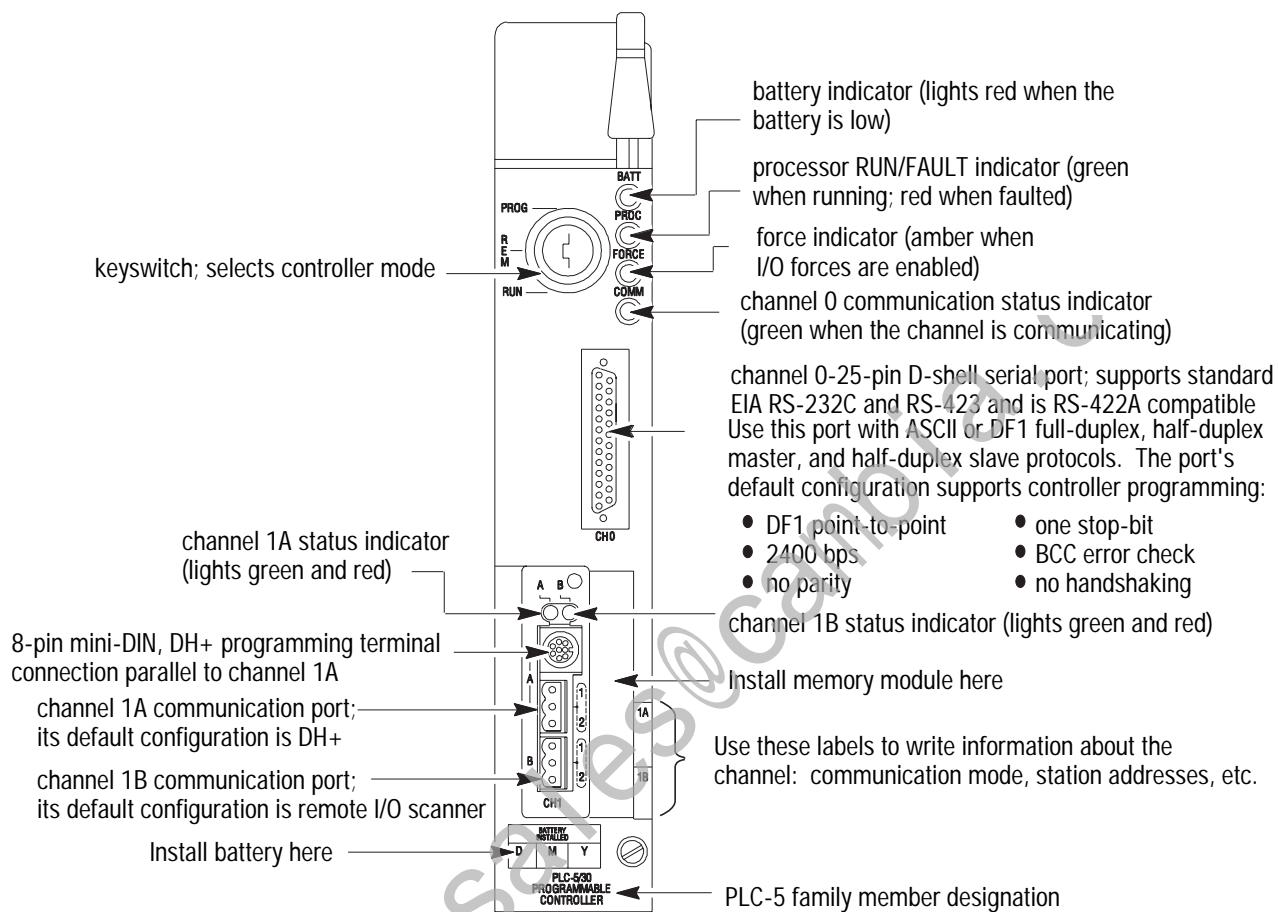



## PLC-5/40, -5/46, -5/60, -5/80, and -5/86 Controller Front Panels

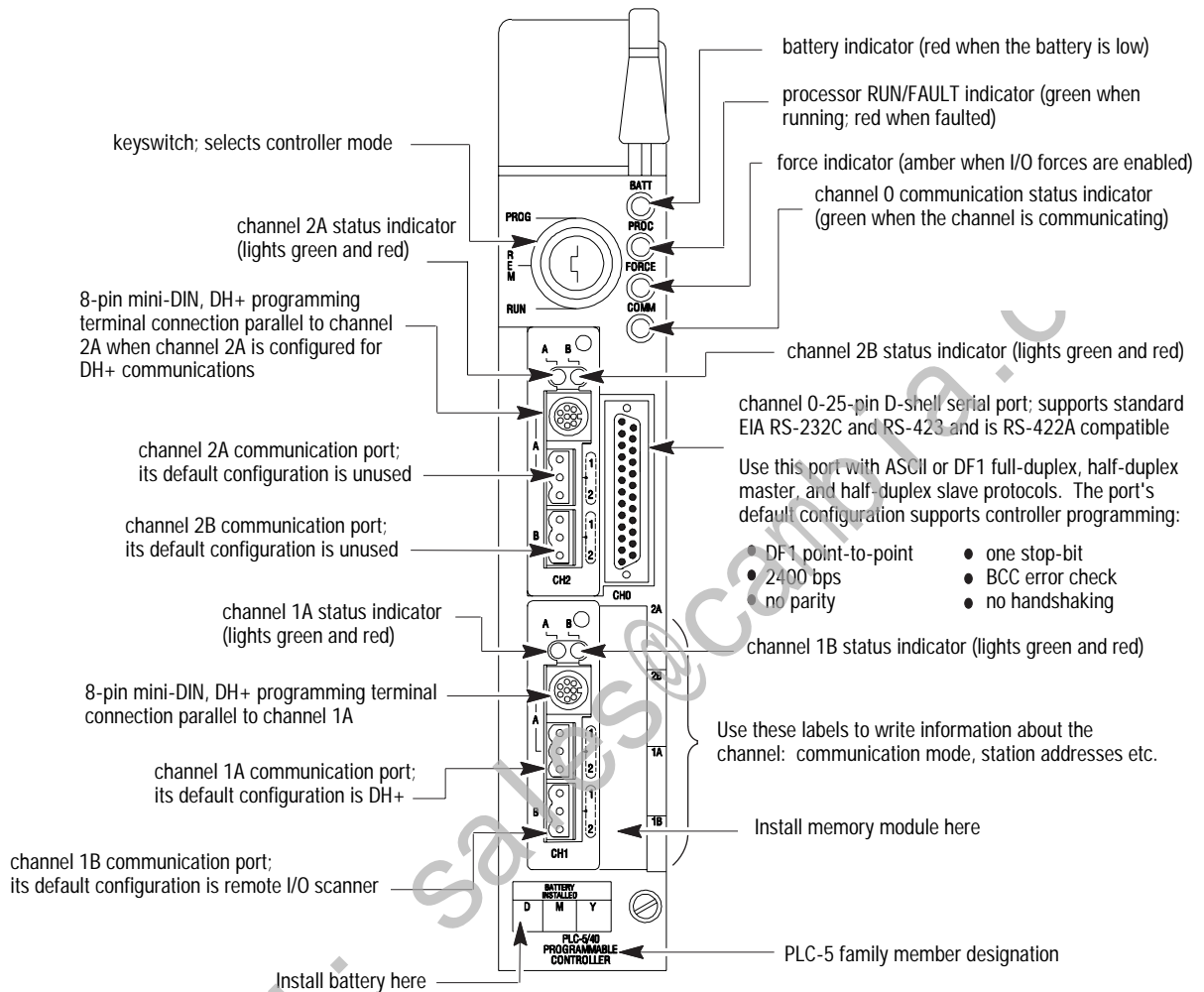

## Additional System Components

Along with your Enhanced PLC-5 programmable controller, you need the following components to complete a basic system:

Product name	Cat. No.
lithium battery	1770-XYC
I/O chassis	1771-A1B, -A2B, -A3B, -A3B1, -A4B
power supply	1771-P4S, -P6S, -P4S1, -P6S1
personal computer	

### IMPORTANT

In this document, we assume you are using a brand-new Enhanced PLC-5 programmable controller.

## Install the System Hardware

This illustration shows a basic Enhanced PLC-5 programmable controller system.

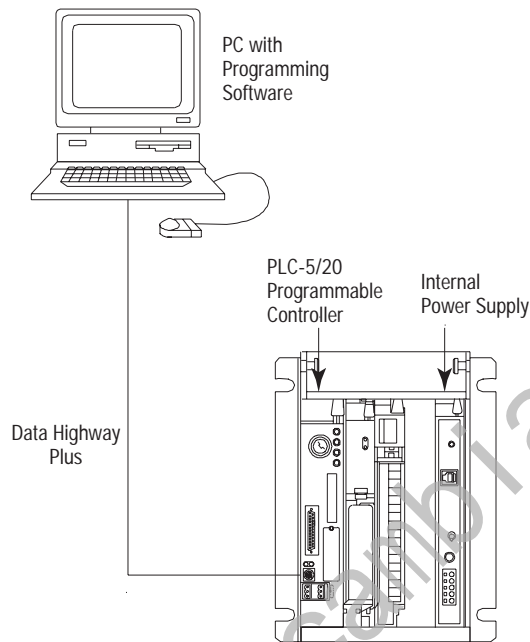

For more information, see the Enhanced and Ethernet PLC-5 Programmable Controllers User Manual, publication number 1785-UM012.

## Prevent Electrostatic Discharge

### ATTENTION



This equipment is sensitive to electrostatic discharge that can cause internal damage and affect normal operation. Follow these guidelines when you handle this equipment:

- touch a grounded object to discharge potential static
- wear an approved grounding wrist strap
- do not touch connectors or pins on component boards
- do not touch circuit components inside the equipment
- if available, use a static-safe workstation
- when not in use, store the equipment in appropriate static-safe packaging

## Prepare to Install the Controller

Installing the controller is one part of setting up the hardware in your system.

---

**WARNING**



If you either insert or remove any module while backplane power is on, OR connect or disconnect any cable with power applied to this module or the device on the other end of the cable, an electrical arc can occur. This could cause an explosion in hazardous location installations. Be sure that power is removed or the area is nonhazardous before proceeding.

---

To properly install the controller, you must follow these procedures in the order described in this section:

1. Install an I/O chassis.
2. Configure the I/O chassis.
3. Install the power supply.
4. Install the PLC-5 programmable controller.
5. Install the I/O modules.
6. Apply power to the system.
7. Connect the personal computer to the PLC-5 programmable controller.

### *Install an I/O Chassis*

Install an I/O chassis according to the Universal I/O Chassis Installation Instructions, pub. no. 1771-IN075.

## Configure the I/O Chassis

Configure the I/O chassis by doing the following:

### 1. Set the backplane switches.

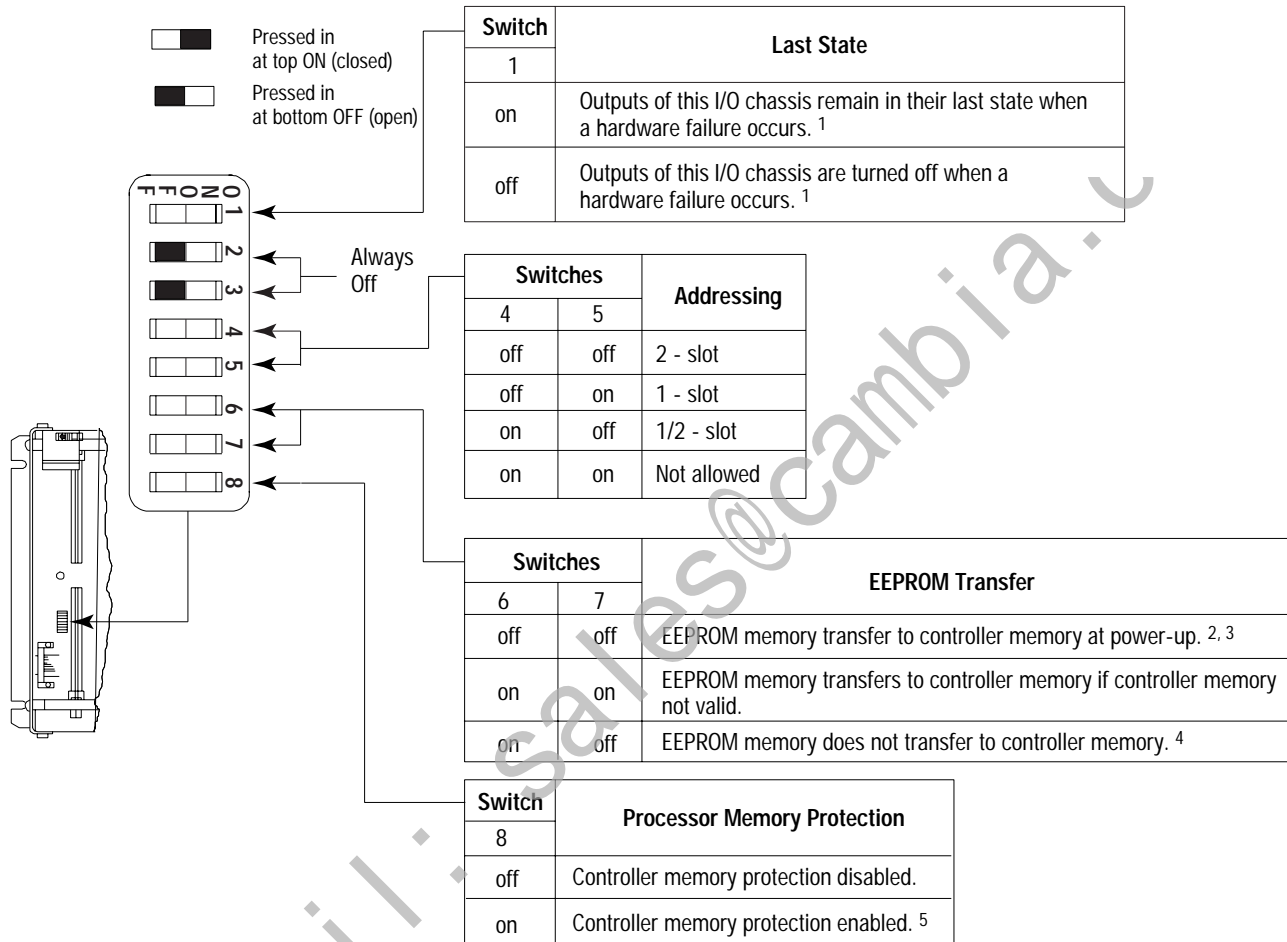

<sup>1</sup> Regardless of this switch setting, outputs are turned off when any of the following occurs:

- controller detects a runtime error
- an I/O chassis backplane fault occurs
- you select program or test mode
- you set a status file bit to reset a local rack

<sup>2</sup> If an EEPROM module is not installed and controller memory is valid, the controller's PROC LED indicator blinks, and the processor sets S:11/9, bit 9 in the major fault status word. To clear this fault, change the controller from program mode to run mode and back to program mode.

<sup>3</sup> If the controller's keyswitch is set in REMote, the controller enters remote RUN after it powers up and has its memory updated by the EEPROM module.

<sup>4</sup> A processor fault (solid red PROC LED) occurs if processor memory is not valid.

<sup>5</sup> You cannot clear processor memory when this switch is on.

2. Set the power supply configuration jumper and set the keying bands as shown below.

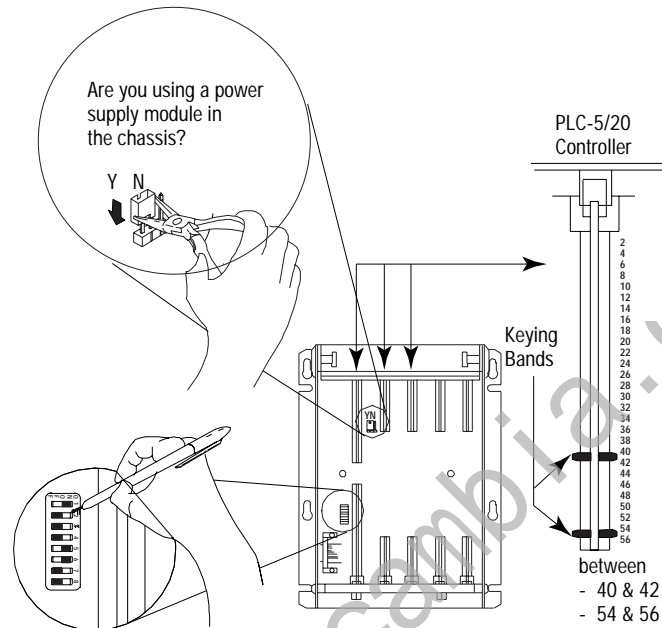

**TIP**

Configuring an I/O rack for a local controller is different than configuring a remote I/O rack using a 1771-ASB module. For more information about configuring a remote I/O rack using a 1771-ASB module, see the following:

- Remote I/O Adapter Module User Manual, publication number, 1771-6.5.83
- Enhanced and Ethernet PLC-5 Programmable Controllers User Manual, publication number 1785-UM012

For more information, see the Universal I/O Chassis installation instructions, publication number 1771-IN075.

**Install the Power Supply**

Install a power supply according to one of the following corresponding installation instructions:

Install this Power Supply:	According to this Publication:
1771-P4S	Power Supply Modules Installation Instructions, pub. no. 1771-2.135
1771-P6S	
1771-P4S1	
1771-P6S1	
1771-P7	Power Supply Module Installation Instructions, pub. no. 1771-IN056

### Install the PLC-5 Programmable Controller

The controller is a modular component of the 1771 I/O system requiring a properly installed system chassis. Refer to publication 1771-IN075 for detailed information on acceptable chassis along with proper installation and grounding requirements. Limit the maximum adjacent slot power dissipation to 10W.

1. Define the DH+ Station Address of Channel 1A by setting switch assembly SW-1 on the back of the controller. See the side of the controller if you want to use another address.

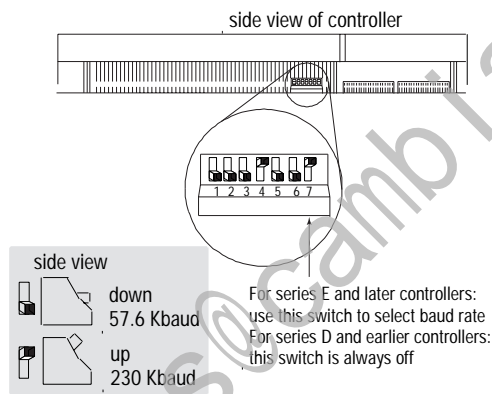

2. Specify the digital interface of Channel 0.

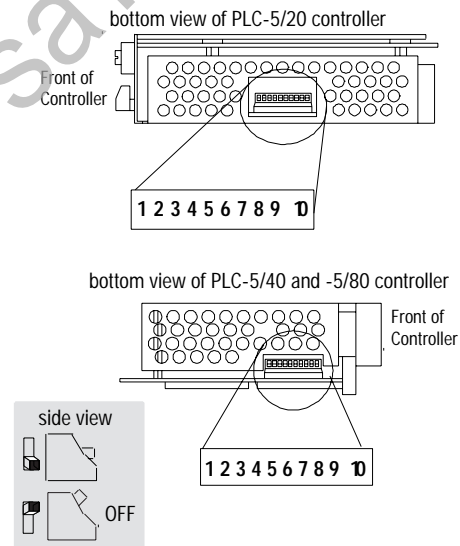

3. Depending on your controller catalog number, install the battery as shown below:

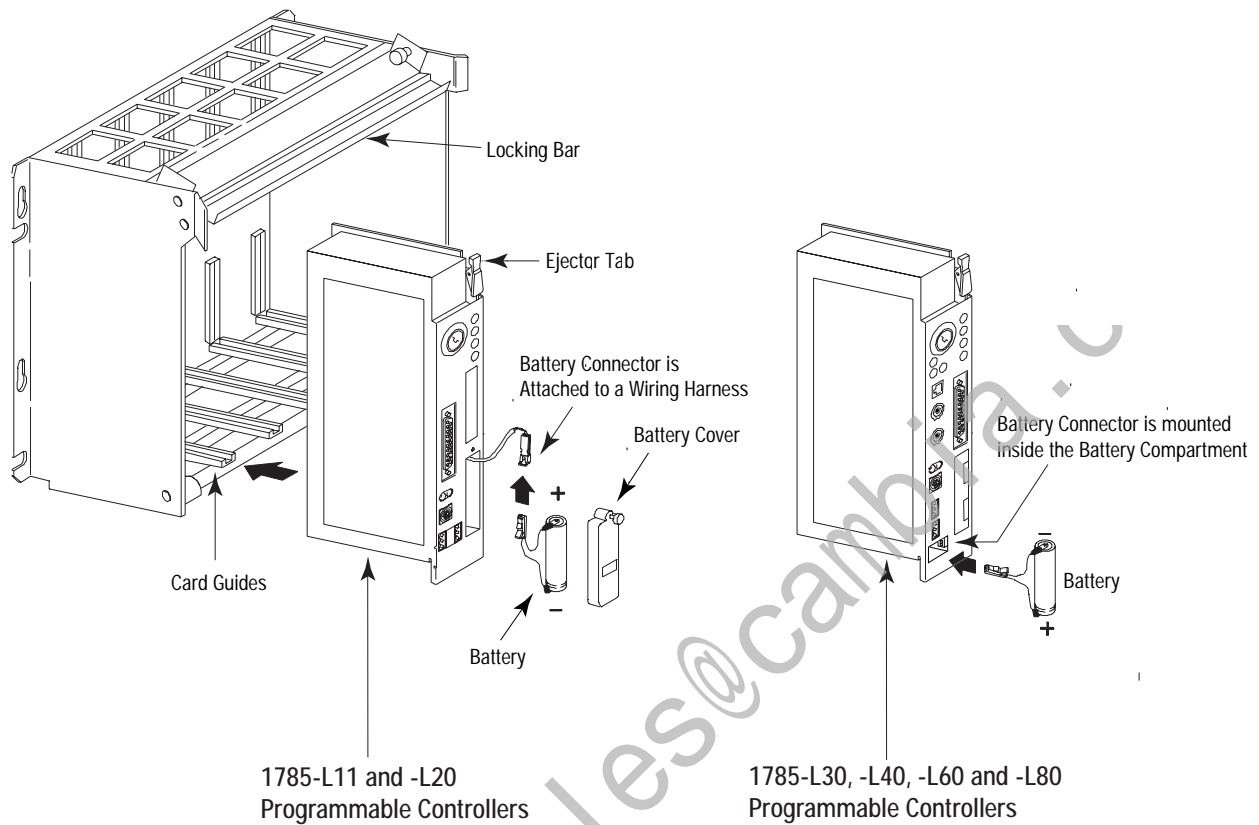

**WARNING**



When you connect or disconnect the battery, an electrical arc can occur. This could cause an explosion in hazardous location installations. Be sure that power is removed or the area is nonhazardous before proceeding. For safety information on the handling of lithium batteries, including handling and disposal of leaking batteries, see Guidelines for Handling Lithium Batteries, publication AG-5.4.

4. Attach the battery cover.
5. Install the controller as shown above.

For more information, see the Enhanced and Ethernet PLC-5 Programmable Controllers User Manual, publication number 1785-UM012.

### Install the I/O Modules

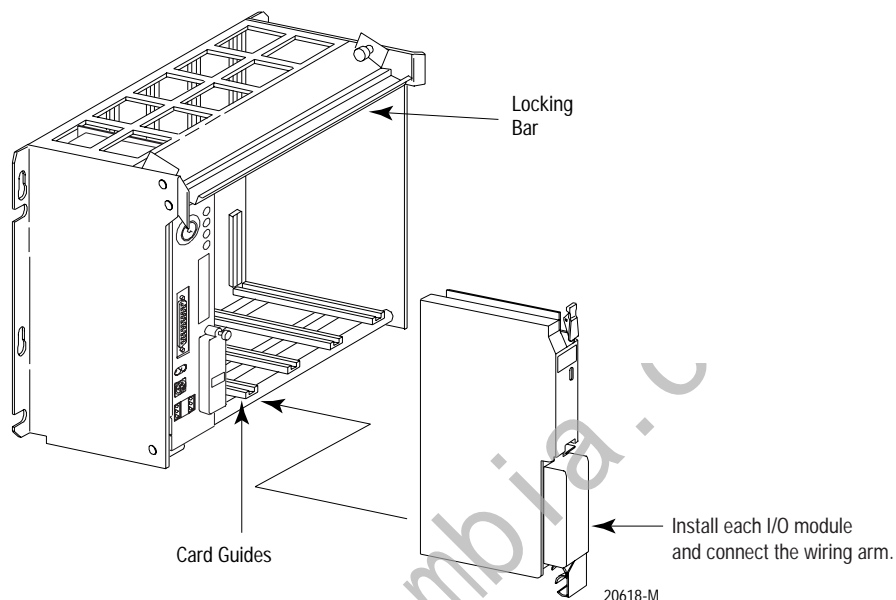

For more information, see the installation instructions or user manual for the particular module you are installing.

### Apply Power to the System

Apply power to the system. Check the LED display on the controller. If your system is operating properly, the PROC LED should be steady red and the message "Processor RAM is faulted. Press <Enter> to clear memory" should appear on the programming software display. See the following table to proceed. If the PROC LED is not off, turn to the next page for troubleshooting information.

If your keyswitch is in this position:	Do this:
PROGRAM	Clear memory. The PROC LED should turn off. The software is in Program mode.
REMOTE	Clear memory. The PROC LED should turn off. The software is in Remote Program mode.
RUN	You see the message "No access or privilege violation" because you cannot clear memory in Run mode. Change the keyswitch position to Program or Remote and press <Enter> to clear memory.



To monitor your system as you configure and run it, check the controller LED display for the following indicators:

<b>This LED:</b>	<b>Lights when:</b>
COMM	you establish serial communication (CH 0)
BATT	no battery is installed or the battery voltage is low
REM I/O	you establish Remote I/O communication
ADAPT	the controller is in adapter mode
FORCE	forces are present in your ladder program

### ***Connect the Personal Computer to the PLC-5 Programmable Controller***

For more information, see:

- Enhanced and Ethernet PLC-5 Programmable Controllers User Manual, publication number 1785-UM012
- the documentation provided with your communication card
- Data Highway/Data Highway Plus/Data Highway II/Data Highway 485 Cable Installation Manual, publication 1770-6.2.2

## Troubleshoot the Controller Use the controller's status indicators with the following tables for diagnostics and troubleshooting.

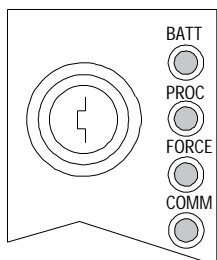

Indicator	Color	Description	Probable Cause	Recommended Action
BATT	Red	Battery low	Battery low	Replace battery within 10 days
	Off	Battery is good	Normal operation	No action required
PROC	Green (steady)	Processor is in run mode and fully operational	Normal operation	No action required
	Green (blinking)	Processor memory is being transferred to EEPROM	Normal operation	No action required
	Red (blinking)	Major fault	RSLogix 5 download in progress  Run-time error	During RSLogix 5 download, this is normal operation - wait for download to complete.  If not during RSLogix 5 download:  Check major fault bit in status file (S:11) for error definition  Clear fault, correct problem, and return to run mode
Alternating Red and Green	Processor in FLASH-memory programming mode	Normal operation if processor's FLASH memory is being reprogrammed	No action required - allow flash update to complete	

Continued on next page

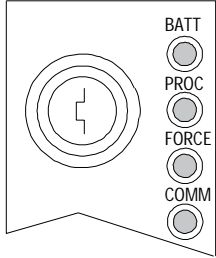

Indicator	Color	Description	Probable Cause	Recommended Action
PROC	Red (steady)	Fault with memory loss	New controller  Processor has failed internal diagnostics	Use programming software to clear and initialize memory  Install battery (to preserve failure diagnostics), then power down, reseal controller and power up; then reload your program. If you are unable to reload your program, replace the controller. If you are able to reload your program and fault persists, contact Technical Support at 440.646.3223 to diagnose the problem.
	Off	Processor is in program load or test mode or is not receiving power	Power supply or connections	Check power supply and connections
FORCE	Amber (steady)	SFC and/or I/O forces enabled	Normal operation	No action required
	Amber (blinking)	SFC and/or I/O forces present but not enabled		
	Off	SFC and/or I/O forces not present		
COMM	Off	No transmission on channel 0	Normal operation if channel is not being used	No action required
	Green (blinking)	Transmission on channel 0	Normal operation if channel is being used	

## Troubleshoot the Controller Communication Channels

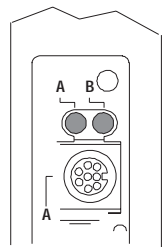

Indicator	Color	Channel Mode	Description	Probable Cause	Recommended Action
A or B	Green (steady)	Remote I/O Scanner	Active Remote I/O link, all adapter modules are present and not faulted	Normal operation	No action required
		Remote I/O Adapter	Communicating with scanner		
		DH+	Controller is transmitting or receiving on DH+ link		
	Green (blinking rapidly or slowly)	Remote I/O Scanner	At least one adapter is faulted or has failed	Power off at remote rack Cable broken	Restore power to the rack Repair cable
		DH+	No other nodes on network		
	Red (steady)	Remote I/O Scanner Remote I/O Adapter DH+	Hardware fault	Hardware error	Turn power off, then on.  Check that the software configurations match the hardware set-up.  Replace the controller.
	Red (blinking rapidly or slowly)	Remote I/O Scanner	Faulted adapters detected	Cable not connected or is broken  Power off at remote racks	Repair cable  Restore power to racks
		DH+	Bad communication on DH+	Duplicate node detected	Correct station address
	Off	Remote I/O Scanner Remote I/O Adapter DH+	Channel offline	Channel is not being used	Place channel online if needed

## Controller Specifications      General Specifications

Backplane Current	PLC-5/11, -5/20, -5/30: 2.3A @ 5Vdc PLC-5/40, -5/40L, -5/46, -5/60, -5/60L, -5/80, -5/86: 3.3A @ 5Vdc
Isolation Voltage	Communication Ports - tested to 500V for 60 seconds Relay Cartridge - tested to 1000V for 60 seconds
Operating Temperature	IEC 60068-2-1 (Test Ad, Operating Cold), IEC 60068-2-2 (Test Bd, Operating Dry Heat), IEC 60068-2-14 (Test Nb, Operating Thermal Shock): 0-60°C (32-140°F)
Storage Temperature	IEC 60068-2-1 (Test Ab, Un-packaged Non-operating Cold), IEC 60068-2-2 (Test Bc, Un-packaged Non-operating Dry Heat), IEC 60068-2-14 (Test Na, Un-packaged Non-operating Thermal Shock): -40 to 85°C (-40 to 185°F)
Relative Humidity	IEC 60068-2-30 (Test Db, Un-packaged Non-operating Damp Heat): 5-95% non condensing
Vibration	IEC60068-2-6 (Test Fc, Operating): 2g @10-500Hz
Shock	IEC60068-2-27:1987, (Test Ea, Unpackaged shock): Operating - 30g Non-operating - 50g
Emissions	CISPR 11: Group 1, Class A (with appropriate enclosure)
ESD Immunity	IEC 61000-4-2: 4kV contact discharges
Radiated RF Immunity	IEC 61000-4-3: 10V/m, with 1kHz sine-wave 80% AM from 30MHz to 1000Mhz
EFT/B Immunity	IEC 61000-4-4: +2kV at 5kHz on communications ports
Surge Transient Immunity	IEC 61000-4-5: +2kV line-earth(CM) on communications ports
Conducted RF Immunity	IEC 61000-4-6: 10Vrms with 1kHz sine-wave 80%AM from 150kHz to 30MHz
Enclosure Type Rating	None (open style)
Time-of-Day Clock/Calendar <sup>1</sup>	Maximum Variations at 60× C: ± 5 min per month Typical Variations at 20× C: ± 20 s per month Timing Accuracy: 1 program scan
Available Cartridges	1785-RC Relay Cartridge
Battery	Allen-Bradley 1770-XYC
Memory Modules	<ul style="list-style-type: none"> <li>• 1785-ME32</li> <li>• 1785-ME64</li> <li>• 1785-M100</li> </ul>
I/O Modules	Bulletin 1771 I/O, 1794 I/O, 1746 I/O, and 1791 I/O including 8-, 16-, 32-pt, and intelligent modules

Specifications continued on next page

## Specifications (continued)

Hardware Addressing	2-slot <ul style="list-style-type: none"> <li>• Any mix of 8-pt modules</li> <li>• 16-pt modules must be I/O pairs</li> <li>• No 32-pt modules</li> </ul> 1-slot <ul style="list-style-type: none"> <li>• Any mix of 8- or 16-pt modules</li> <li>• 32-pt modules must be I/O pairs</li> </ul> 1/2-slot—Any mix of 8-, 16-, or 32-pt modules	
Communication	<ul style="list-style-type: none"> <li>• Serial</li> <li>• DH+ (trunk line: 3048 cable-m (10,000 cable-ft) drop line: 30.4 cable-m (100 cable-ft))</li> <li>• DH using 1785-KA</li> <li>• Remote I/O</li> </ul>	Wiring Category 2 <sup>2</sup>
	<ul style="list-style-type: none"> <li>• extended-local I/O (PLC-5/40L and -5/60L controllers only)</li> </ul>	Wiring Category 3 <sup>2</sup>
	<ul style="list-style-type: none"> <li>• Relay Cartridge</li> </ul>	Wiring Category 1 <sup>2</sup>
Location	1771-A1B, -A2B, A3B, -A3B1, -A4B chassis; left-most slot	
Weight	PLC-5/20, -5/26, -5/30: 3 lbs, 3 oz (1.45 kg) PLC-5/40, -5/40L, -5/46: 3 lbs, 2 oz (1.42 kg) PLC-5/60, -5/60L: 3 lbs, 2 oz (1.42 kg) PLC-5/80, -5/86: 3 lbs, 2 oz (1.42 kg)	
Certifications <sup>3</sup> (when product is marked)	UL      UL Listed Industrial Control Equipment CSA      CSA Certified Process Control Equipment CSA      CSA Certified Process Control Equipment for Class I, Division 2 Group A,B,C,D Hazardous Locations  CE      European Union 89/336/EEC EMC Directive, compliant with: EN 50082-2: Industrial Immunity EN 61326; Meas./Control/Lab. Industrial Requirements EN 61000-6-2: Industrial Immunity EN 61000-6-4: Industrial Emissions  C-Tick   Australian Radiocommunications Act, compliant with: AS/NZS CISPR 11: Industrial Emissions	

### 1785-L40B Controller - European Hazardous Location Approval European Zone 2 Certification (The following applies when the product bears the EEx Marking)

This equipment is intended for use in potentially explosive atmospheres as defined by European Union Directive 94/9/EC. The LCIE (Laboratoire Central des Industries Electriques) certifies that this equipment has been found to comply with the Essential Health and Safety Requirements relating to the design and construction of Category 3 equipment intended for use in potentially explosive atmospheres, given in Annex II to this Directive. The examination and test results are recorded in confidential report No. 28 682 010.

Compliance with the Essential Health and Safety Requirements has been assured by compliance with EN 50021.

#### IMPORTANT

- This equipment is not resistant to sunlight or other sources of UV radiation.
- The secondary of a current transformer shall not be open-circuited when applied in Class I, Zone 2 environments.
- Equipment of lesser Enclosure Type Rating must be installed in an enclosure providing at least IP54 protection when applied in Class I, Zone 2 environments.
- This equipment shall be used within its specified ratings defined by Allen-Bradley.
- Provision shall be made to prevent the rated voltage from being exceeded by transient disturbances of more than 40% when applied in Class I, Zone 2 environments.

<sup>1</sup> The clock/calendar will update appropriately each year.

<sup>2</sup> For more information, refer to publication 1770-4.1, *Industrial Automation Wiring and Grounding Guidelines*.

<sup>3</sup> See the Product Certification link at [www.ab.com](http://www.ab.com) for Declarations of Conformity, Certificates, and other certification details

## Battery Type

Enhanced PLC-5 programmable controllers use 1770-XYC batteries that contain 0.65 grams of lithium.

### *Average Battery Lifetime Specifications*

In this controller:	At this temperature:	Worst-case battery life estimates		
		Power off 100%	Power off 50%	Battery duration after the LED lights <sup>1</sup>
PLC-5/11, -5/20	60°C	256 days	1.4 years	11.5 days
	25°C	2 years	4 years	47 days
PLC-5/30, -5/40, -5/40L, -5/60, -5/60L, -5/80	60°C	84 days	150 days	5 days
	25°C	1 year	1.2 years	30 days

<sup>1</sup> The battery indicator (BATT) warns you when the battery is low. These durations are based on the battery supplying the only power to the controller (power to the chassis is off) once the LED first lights.

## Memory and Channel Specifications

This table lists memory and channel specifications of each Enhanced and extended-local PLC-5 programmable controller.

Cat. No.	Maximum User Memory (words)	Total I/O Maximum	Channels	Maximum Number of I/O Chassis				Power Dissipation, Maximum	Backplane Current Load
				Total	Extended-Local	Remote	ControlNet		
1785-L11B	8K	512 any mix <b>or</b> 384 in + 384 out (complement)	1 DH+/remote I/O	5	0	4	0	12W	2.3A
1785-L20B	16K	512 any mix <b>or</b> 512 in + 512 out (complement)	1 DH+ 1 DH+/remote I/O	13	0	12	0	12W	2.3A
1785-L30B	32K	1024 any mix <b>or</b> 1024 in + 1024 out (complement)	2 DH+/remote I/O	29	0	28	0	12W	2.3A
1785-L40B	48K	2048 any mix <b>or</b> 2048 in + 2048 out (complement)	4 DH+/remote I/O	61	0	32 max/link	0	17.3W	3.3A
1785-L60B	64K	3072 any mix <b>or</b> 3072 in + 3072 out (complement)	4 DH+/remote I/O	93	0	32 max/link	0	17.3W	3.3A
1785-L80B	100K	3072 any mix <b>or</b> 3072 in + 3072 out (complement)	4 DH+/remote I/O	93	0	32 max/link	0	17.3W	3.3A



## Rockwell Automation Support

Rockwell Automation provides technical information on the web to assist you in using our products. At <http://support.rockwellautomation.com>, you can find technical manuals, a knowledge base of FAQs, technical and application notes, sample code and links to software service packs, and a MySupport feature that you can customize to make the best use of these tools.

For an additional level of technical phone support for installation, configuration and troubleshooting, we offer TechConnect Support programs. For more information, contact your local distributor or Rockwell Automation representative, or visit <http://support.rockwellautomation.com>.

## Installation Assistance

If you experience a problem with a hardware module within the first 24 hours of installation, please review the information that's contained in this manual. You can also contact a special Customer Support number for initial help in getting your module up and running:

United States	1.440.646.3223 Monday – Friday, 8am – 5pm EST
Outside United States	Please contact your local Rockwell Automation representative for any technical support issues.

## New Product Satisfaction Return

Rockwell tests all of our products to ensure that they are fully operational when shipped from the manufacturing facility. However, if your product is not functioning and needs to be returned:

United States	Contact your distributor. You must provide a Customer Support case number (see phone number above to obtain one) to your distributor in order to complete the return process.
Outside United States	Please contact your local Rockwell Automation representative for return procedure.

[www.rockwellautomation.com](http://www.rockwellautomation.com)

### Power, Control and Information Solutions Headquarters

Americas: Rockwell Automation, 1201 South Second Street, Milwaukee, WI 53204-2496 USA, Tel: (1) 414.382.2000, Fax: (1) 414.382.4444

Europe/Middle East/Africa: Rockwell Automation, Vorstlaan/Boulevard du Souverain 36, 1170 Brussels, Belgium, Tel: (32) 2 663 0600, Fax: (32) 2 663 0640

Asia Pacific: Rockwell Automation, Level 14, Core F, Cyberport 3, 100 Cyberport Road, Hong Kong, Tel: (852) 2887 4788, Fax: (852) 2508 1846

Publication 1785-IN062A-EN-P - May 2005

Supersedes Publication 1785-10.4 - November 1998

PN 957689-58

Copyright © 2005 Rockwell Automation, Inc. All rights reserved. Printed in the U.S.A.